

Ikonic Tankless Screen Guide

INSTRUCTIONS FOR THE INSTALLER

Condensing Tankless with Integrated Recirculation
199,900 Btu/hr, 180,000 Btu/hr and 157,000 Btu/hr Models

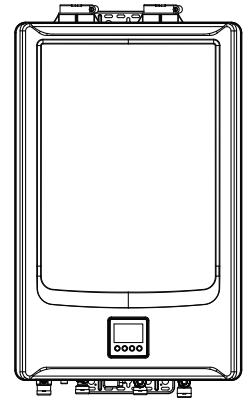

⚠️ WARNING:

If the information in these instructions is not followed exactly, a fire or explosion may result, causing death, personal injury, or property damage.

⚠️ For Your Safety!

- Do not store or use gasoline or other flammable vapors and liquids in the vicinity of this or any other appliance. To do so may result in an explosion or fire.
- Installation and service must be performed by a qualified installer, service agency, or the gas supplier.

What to Do If You Smell Gas

- Do not try to light any appliance.
- Do not touch any electrical switch; do not use any phone in your building.
- Immediately call your gas supplier from a neighbor's phone. Follow the gas supplier's instructions.
- If you cannot reach your gas supplier, call the fire department.
- Do not return to your home until authorized by the gas supplier or fire department.

Do not destroy manual. Please read carefully and keep in a safe place for future reference.

Print 2D
Bar Code
Here

INSTALLATION INSTRUCTIONS

Factory Settings

The default settings of this water heater are as follows:

FACTORY SETTINGS	
Set temp.	120°F
Recirc Pump Mode	None
Manifold Heaters	1
Water Saver Mode	OFF
Elevation	Sea Level
Temp. Unit	Fahrenheit
Service Alert	OFF
Beep on Alarm	OFF
Display	DISABLED

INSTALLATION INSTRUCTIONS

Multiple Unit Controls

For installation of multiple water heaters, ensure proper manifolding of the controls and common venting as outlined in the section below. Note that up to 20 water heaters can have manifolded gas lines, water lines, and controls, however, vent pipes can only be common vented for a maximum of 2 water heaters. For more than 2 water heater installations, multiple vent runs will be required. For manifold systems with built-in recirculation pump, the first water heater in the series must contain the built-in recirculation pump to ensure proper operation. Additional water heaters in the series can be recirculation or non-recirculation based on application requirements.

This water heater includes multiple unit controls to manifold up to 20 water heaters together. To accomplish multiple unit controls, a RJ25 communication cable(s) is required. Contact a store where tankless water heaters were purchased to purchase the RJ25 communication cable(s).

Suggested RJ25 Communication Cables	
Part Number	Length
RCPN-AMP03-0013111101-003	48"
RCPN-AMP03-0013111101-002	72"
RCPN-AMP03-0013111101-004	240"

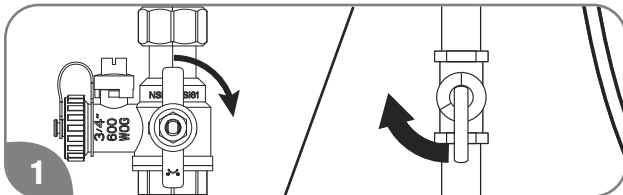

Turn off water and gas.

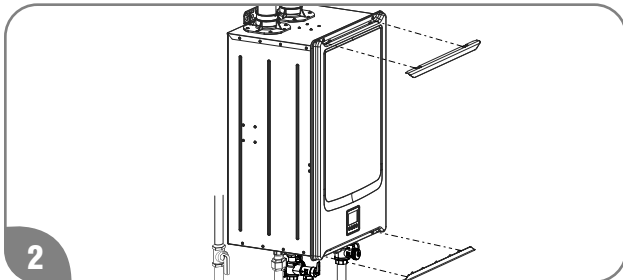

Remove screw covers, 4 screws, and a front cover for all water heaters.

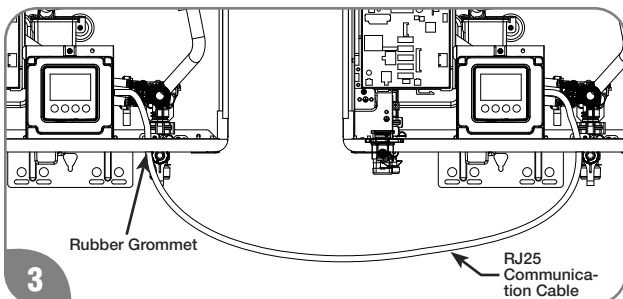

Connect all water heaters by the RJ25 Communication Cable(s). The RJ25 Communication Cable(s) should go through a rubber grommet on the bottom of the water heater, and be attached to one of the connectors on the right side of the display. The other end should be attached to another water heater.

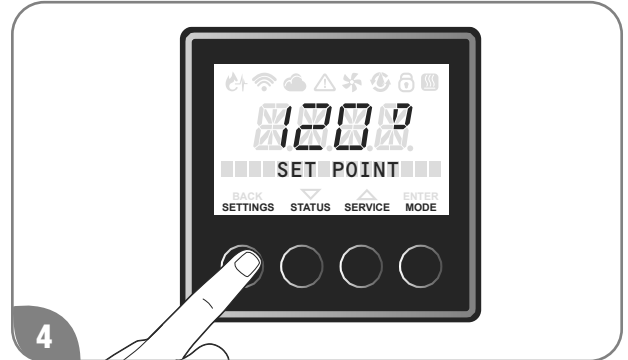

Go to a display on one of the units, and press "SETTINGS".

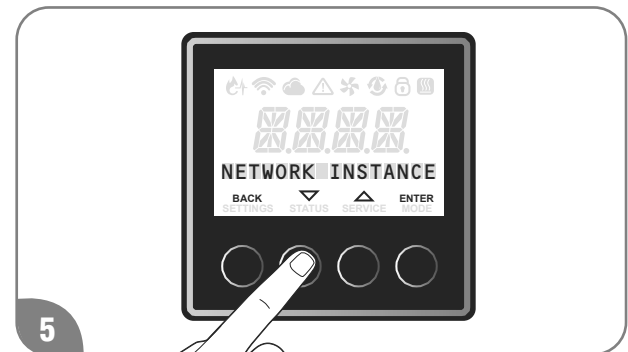

Press the "▼" or "▲" button until "NETWORK INSTANCE" is displayed, and press "ENTER" to confirm.

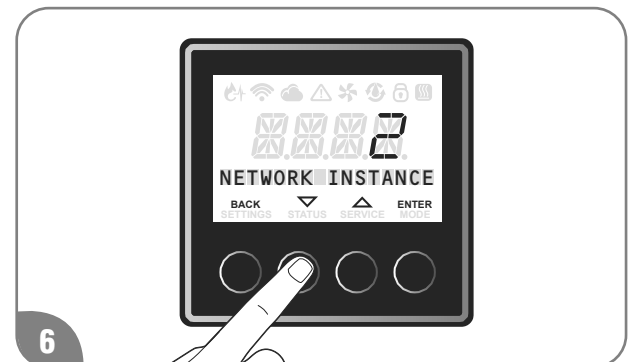

Press the "▼" or "▲" button for several times to assign a unique and sequential instance number to the unit, and press "ENTER" to confirm. Repeat steps 4 through 6 until all manifolded units are assigned to a unique instance number.

INSTALLATION INSTRUCTIONS



Multiple Unit Controls (cont.)



7 Go to a display on a unit with "INSTANCE" = 1, and press "SETTINGS".



8 Press the "▼" or "▲" button until "Tankless Config" is displayed, and press "ENTER" to confirm.



9 Press the "▼" or "▲" button until "Manifolded Heaters" is displayed, and press "ENTER" to confirm.



10 Press the "▼" or "▲" button to set a number of manifolded water heaters, and click "ENTER" to confirm.



11 Confirm the label "MASTER" is visible on the display of unit instance 2, and "MANIFOLD #*" is visible on display of instance * unit where * is the unit's instance number. If set up is not completed properly and you don't see the text, repeat steps 3 through 10.



12 Instance 1 will remain with the text "SET POINT" displayed on the main screen. Only Instance 1 is used to control the set point of all the manifolded units.

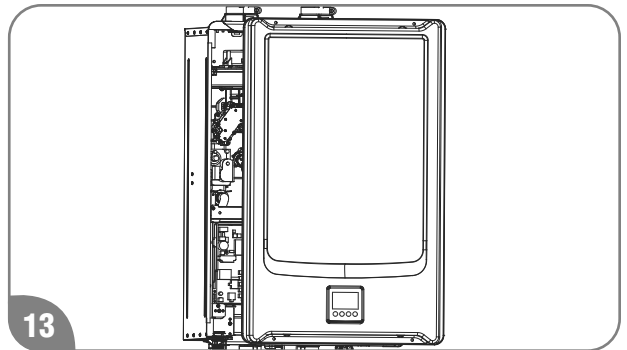

13 Install the front cover, 4 screws and the screw covers for all water heaters.



14 Turn on water and gas.

INSTALLATION INSTRUCTIONS

Service Alert

Service alert reminds users of water heater maintenance activities such as flushing the heat exchanger or replacing the water treatment filter (if applicable) in order to maximize the life of your tankless water heater. In addition to those maintenance activities, conduct inspections, care cleaning and preventive maintenance activities refer to "Water Heater Inspections", "Care and Cleaning" and "Preventive Maintenance" in this Use and Care Manual. Contact technical service department listed on page 93 of this use and care manual if you are not familiar with these maintenance activities.

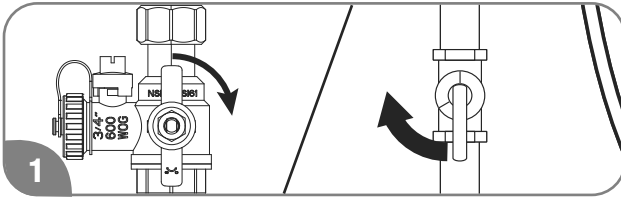

Turn off the gas and water to the water heater by closing the shut-off valves.



Press the "SERVICE" button.



Press the "▼" or "▲" button until "Service Alert" is displayed, and press the "ENTER" button.



The Factory setting is "OFF". Press the "▼" or "▲" button to choose between "500 Hours", "750 Hours" or "1000 Hours" of combustion time for the service alert and press "ENTER" button to confirm.

To exit this setting, press "Back" button until the initial screen is displayed.

NOTICE:

It is recommended not to change default 500 hours unless it is absolutely necessary.



Turn on the gas and water to the water heater by opening the shut off valves.

INSTALLATION INSTRUCTIONS

High-Altitude Adjustments

⚠️WARNING:

When the water heater is installed above 2000ft (610m), the setting on the LCD on the user interface need to be changed altitude. If these setting are not changed, the water heater may not function properly

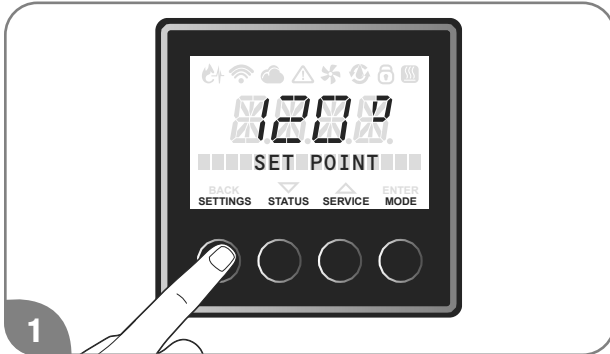

Press the "SETTINGS" button.

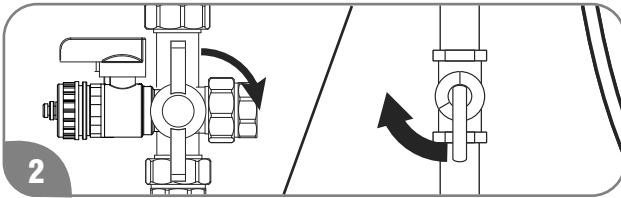

Turn off the gas and water to the water heater by closing the shut-off valves.

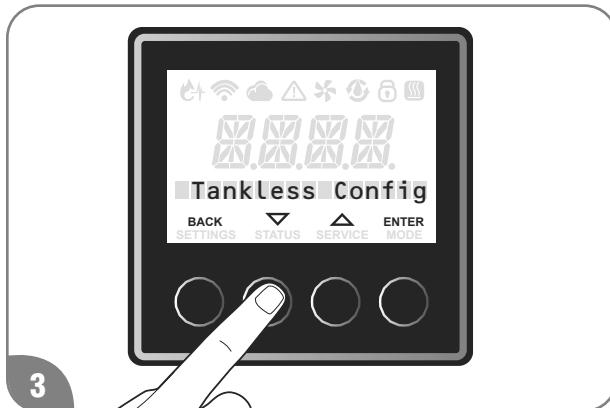

Press the "▼" or "▲" button until "Tankless Config" is displayed, and press the "ENTER" button.

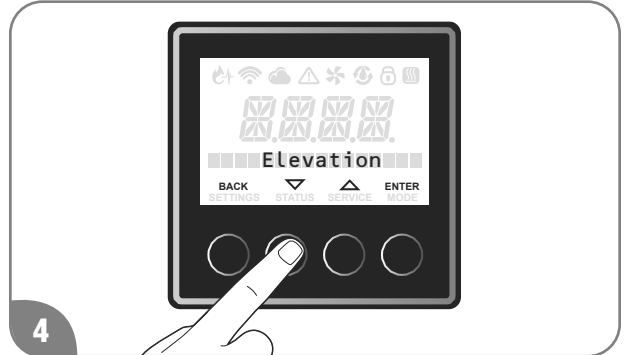

Press the "▼" or "▲" button until "Elevation" is displayed, and press the "ENTER" button.



The Factory setting is "Sea Level".

Press the "▼" or "▲" button to choose "Low Altitude", "Med. Altitude" or "High Altitude", and press the "ENTER" button to confirm.

To exit this setting, press "Back" button until the initial screen is displayed.

SECTION	HIGH-ALTITUDE
Sea Level	0 – 2,000 ft (0 m – 610 m)
Low Altitude	2,001 ft – 5,400 ft (610 m – 1,650 m)
Med. Altitude	5401 ft – 7,900 ft (1,650 m – 2,410 m)
High Altitude	7,901 ft – 10,200 ft (2,410 m – 3,110 m)

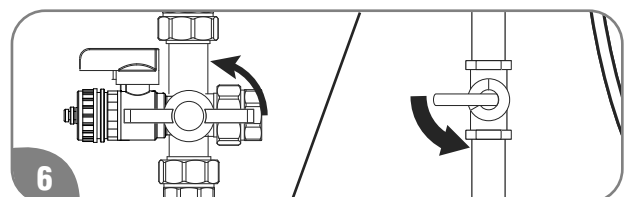

Turn on the gas and water to the water heater by opening the shut off valves.

USING YOUR WATER HEATER



Setting the Water Temperature

⚠️ WARNING:

Improper adjustment, alteration, service, or maintenance can result in death, personal injury, property damage, and/or product damage.

Setting delivered water temperature

⚠️ DANGER:

Water temperatures above 125°F (52°C) will result in death and/or severe burns from scalding.

⚠️ WARNING:

Refer to chart below and the scald potential warnings on page 4 on this manual before making an adjustment. Changing this setting is done at your own risk.

Time/Temperature Relationship in Scalds

Water Temperature	Time to Produce a Serious Burn
120°F (49°C)	More than 5 minutes
125°F (52°C)	1 1/2 to 2 minutes
130°F (54°C)	About 30 seconds
135°F (57°C)	About 10 seconds
140°F (60°C)	Less than 5 seconds
145°F (63°C)	Less than 3 seconds
150°F (66°C)	About 1 1/2 seconds
155°F (68°C)	About 1 second

Table courtesy of Shriners Burn Institute

Residential water heater temperatures can be adjusted up to 140°F (60°C). **DO NOT** perform the following adjustment if a setting of up to 140°F (60°C) is not required.

Temperature Conversion Chart °F/°C (Reference only)

85 100 102 104 106 108 110 112 114 116 118 120 125 130 140 °F
29 38 39 40 41 42 43 44 46 47 48 49 52 54 60 °C

⚠️ DANGER:

Hotter water increases the potential for Hot Water SCALDS.



Display needs to be unlocked before the settings can be changed. Push and hold two buttons in center until beeping sound is heard. Once unlocked the “SETTINGS”, “STATUS” or “SERVICE” menus can be accessed.



Unlocked display shown above

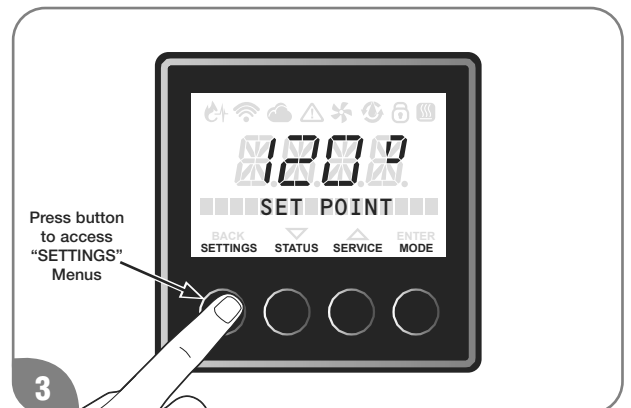

Temperature “SET POINT” can be changed by accessing the “SETTINGS” menu.

USING YOUR WATER HEATER



Setting the Water Temperature

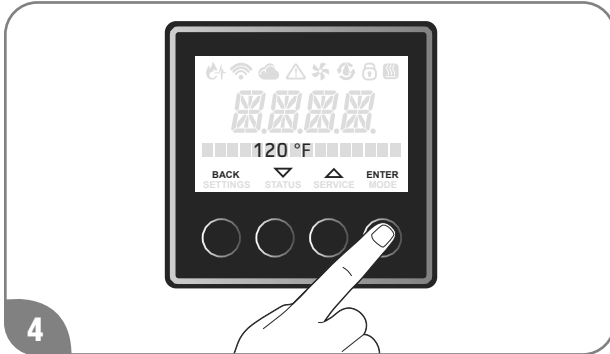

4 After you select "SETTINGS" scroll through the menu to select "SET POINT", to enter the set point mode press "ENTER" button, which is the right most button.

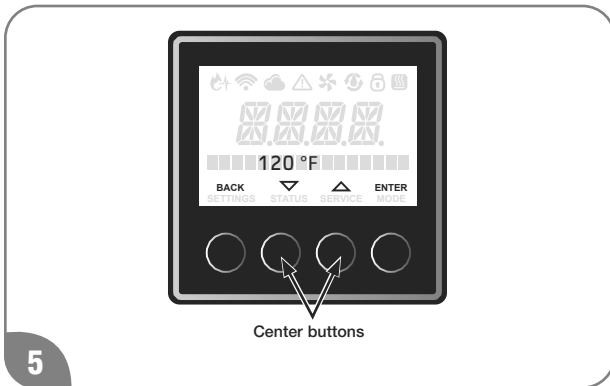

5 Now press the "▼" or "▲" button in the center of the display to increase or decrease the temperature. Temperature can be changed in increments of 1°F.

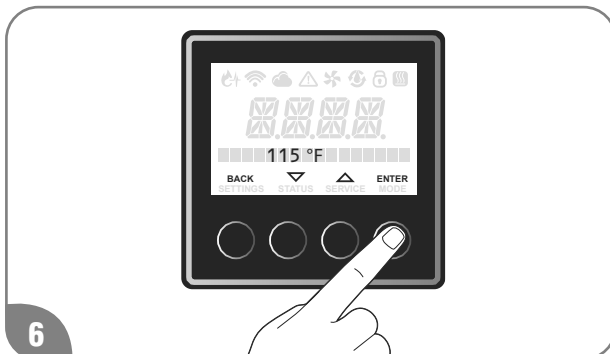

6 Once temperature is set to the desired value, press "ENTER" button, right most button to store value. To exit this setting, press "Back" button until the initial screen is displayed.

How To Change The Temperature Display

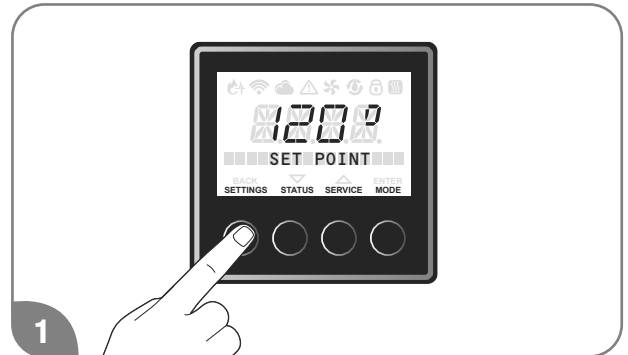

1 Press the "SETTINGS" button.

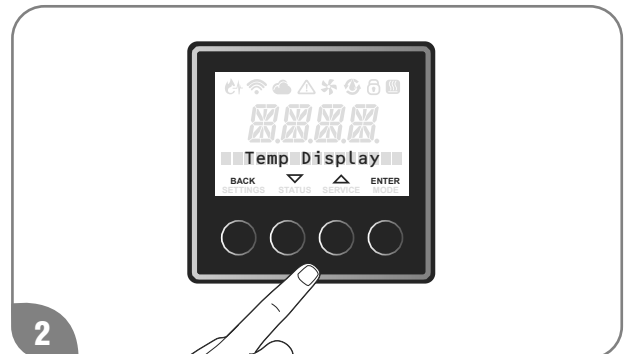

2 Press the "▼" or "▲" button until "Temp Display" is displayed, and press "ENTER" button.

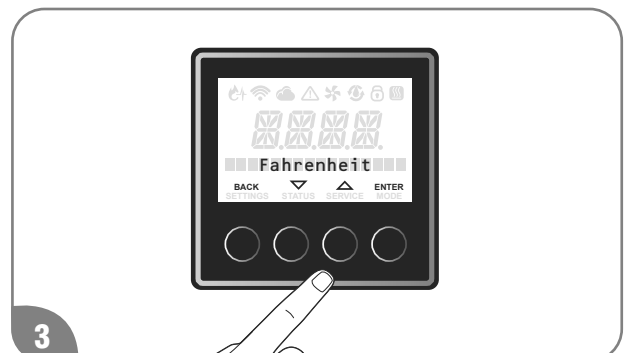

3 The Factory setting is "Fahrenheit". Press the "▼" or "▲" button to select "Fahrenheit" and "Celsius", and press the "ENTER" to confirm.

To exit this setting, press "Back" button until the initial screen is displayed.

USING YOUR WATER HEATER



Recirculation Setting

This section is applicable for pump built-in models, and standard models with an external pump following the pump installation described in this Use and Care manual. If the external pump is installed independently from the water heater, this section is not applicable.

For recirculation setting, timer mode, schedule mode, and on demand mode are available. Timer mode also has Performance mode and Energy Saver mode. Read next several pages to set most suitable mode. Contact service department listed on page 93 of this use and care manual if additional help is needed.

Mode Setting - Timer mode-

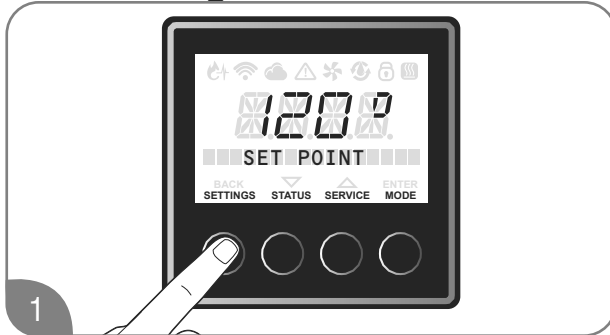

Press the “SETTINGS” button.



Press the “▼” or “▲” button until “Tankless Config” is displayed, and press the “ENTER” button.

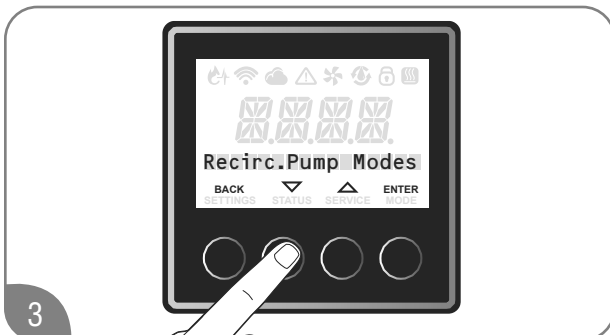

Press the “▼” or “▲” button until “Recirc. Pump Modes” is displayed, and press the “ENTER” button.

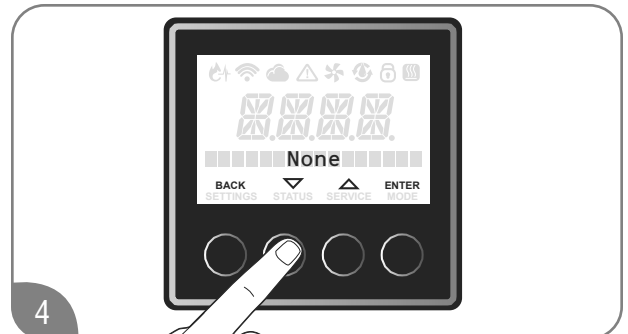

The Factory setting is “None”.

Press the “▼” or “▲” button to select “Timer-Perf” or “Timer-E-Saver” and press the “ENTER” to confirm.

Recirculation Operation -Timer mode -

The water heater is turned ON when the recirculation pump starts operation. The water heater produces hot water at the setting temperature. When the return water temperature reaches approximately 15°F below the setting temperature, the water heater and the pump will turn OFF. The cycle will restart at the approximate time based on the temperature thermistor readings.

Performance mode (Timer-Perf)

The performance mode operates as below;

- Higher energy consumption due to more pump cycles
- Pump cycles ON Every 15 to 30 minutes

Energy Saver mode (Timer E-Saver)

The Energy Saver mode operates as below;

- Less Energy consumption due to fewer pump cycles
- Pump cycles ON Every 30 to 60 minutes

USING YOUR WATER HEATER



Recirculation Setting (Cont.)

Mode Setting - On Demand-

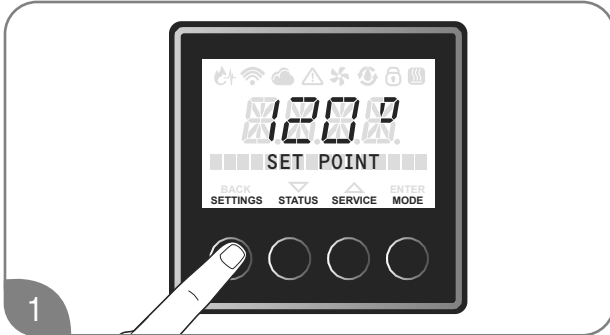

Press the "SETTINGS" button.

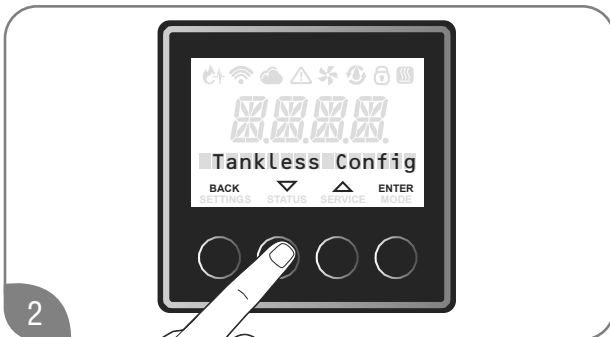

Press the "▼" or "▲" button until "Tankless Config" is displayed, and press the "ENTER" button.

If incorrect setting is entered at any steps, press the "Back" button until the initial screen.

Redo from step 1.

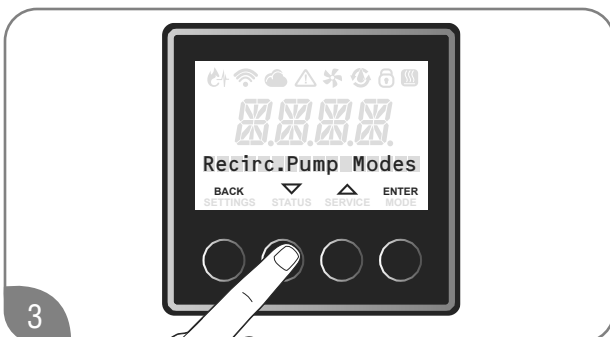

Press the "▼" or "▲" button until "Recirc. Pump Modes" is displayed, and press the "ENTER" button.

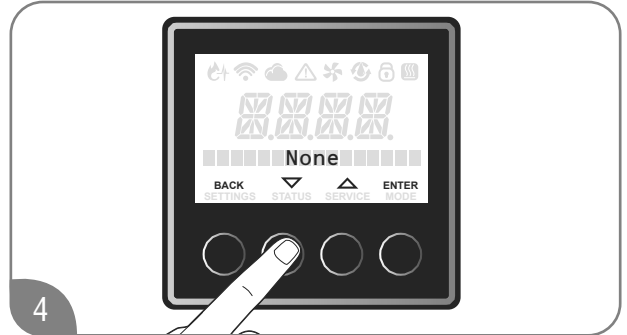

The Factory setting is "None".

Press the "▼" or "▲" button until "On-Demand" is displayed, and press the "ENTER" button.

To exit this setting, press "Back" button until the initial screen is displayed.

Recirculation Operation-On Demand -

The following accessories are needed to use the On-Demand recirculation activation.

Rheem Part Number	Description
SP20862	Motion Sensor Kit
SP20863	Wired Push Button

When set to "On-Demand" mode, the recirculation pump is ON for 5 minutes when the signal from the Motion Sensor or Wired Push Button is received, or until the return water temperature reaches approximately 15°F below the setting temperature.

For information about On-Demand accessories, refer to "If You Need Service" on page 93, "Call For Assistance" for the telephone number to speak to a Customer Service Representative.

USING YOUR WATER HEATER

Recirculation Setting

Mode Setting

-Manually operate pump-

On-Demand mode allows to turn ON the recirculation pump manually.

(Disabled in Timer mode)

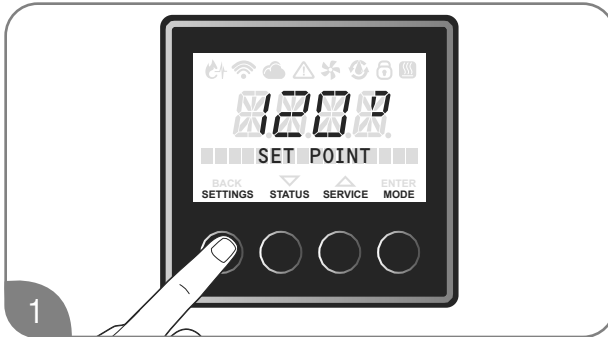

Press the "SETTINGS" button.



Press the "▼" or "▲" button until "Tankless Config" is displayed, and press the "ENTER" button.

If incorrect setting is entered at any steps, press the "Back" button until the initial screen.

Redo from step 1.

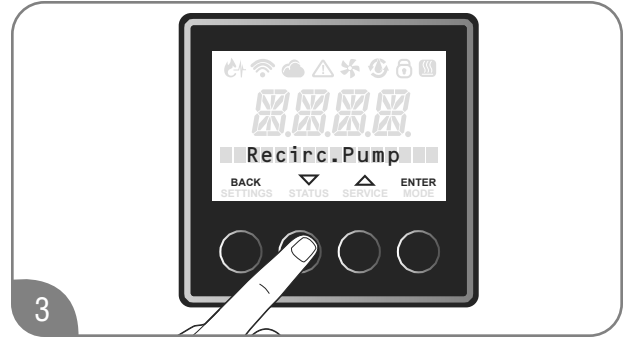

Press the "▼" or "▲" button until "Recirc. Pump" is displayed, and, press the "ENTER" button.

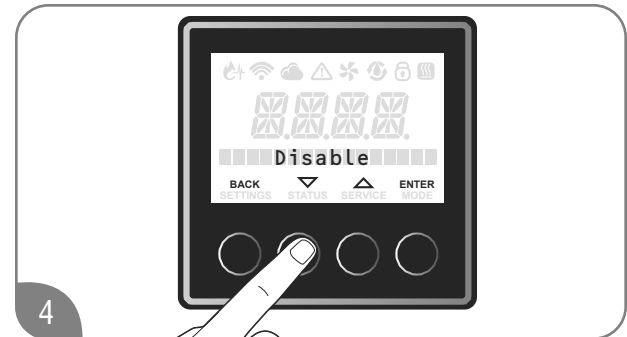

The Factory setting is "Disabled".

Press the "▼" or "▲" button until "Enable" is displayed and press the "Enter" button.

To exit the setting, press "Back" button until the initial screen is displayed.

Recirculation Operation

-Manually operate pump-

When set the "Recirc. Pump" ON, the recirculation pump is ON for 5 minutes or until the return water temperature reaches approximately 15°F below the setting temperature.

USING YOUR WATER HEATER



Recirculation Setting (Cont.)

Mode Setting -Schedule-



Press the "SETTINGS" button.

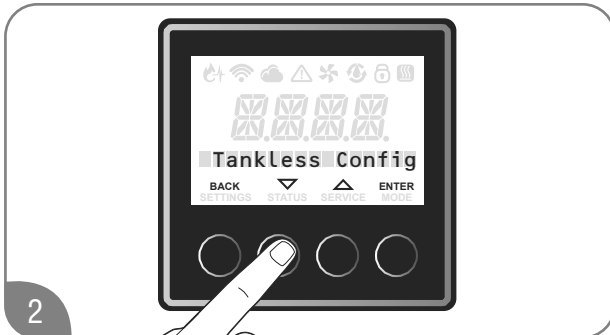

Press the "▼" or "▲" button until "Tankless Config" is displayed, and press the "ENTER" button.

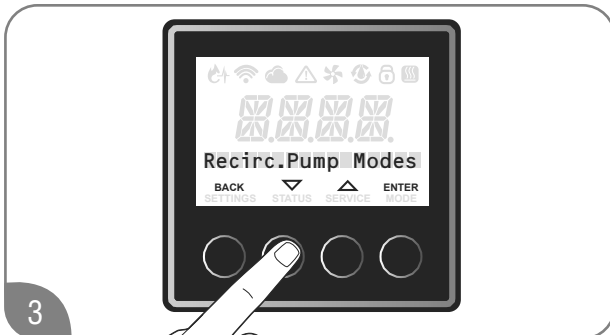

Press the "▼" or "▲" button until "Recirc. Pump Modes" is displayed, and press the "ENTER" button.



The Factory setting is "None"

Press the "▼" or "▲" button until "Schedule" is displayed, and press the "ENTER" button.

To exit this setting, press "Back" button until the initial screen is displayed.

NOTICE:

To use this schedule mode, it is required to set Wi-Fi on this user interface and to download the specific application on your smart phone. Please see "Wi-Fi Setting" in this U&C manual to set Wi-Fi on this user interface and to download the application.

USING YOUR WATER HEATER



WiFi Setting (Select models only)

WiFi Setup (At initial power up)

Display will ask at initial power up if the user wants to Setup WiFi. The user can press ENTER to continue Setup WiFi or BACK to exit setup and turn OFF WiFi signal broadcast.



If need WiFi setup, press “ENTER” button.

WiFi signal is broadcasted for 30 minutes and the user will use the EcoNET Application to continue the setup process. The steps are in the application.

If user chooses to set up WiFi later, press “BACK” button. WiFi signal will not be broadcasted until user goes to additional steps.

WiFi Setup (After initial power up)

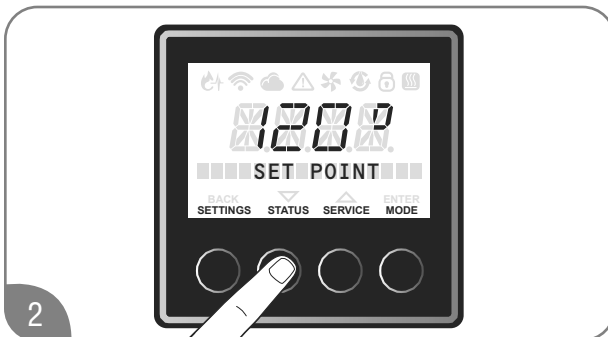

Press the “STATUS” button.

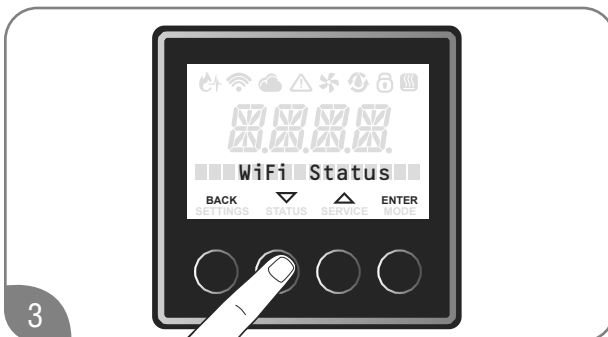

Press the “▼” or “▲” button until “WiFi status” is displayed, and press “ENTER” button.

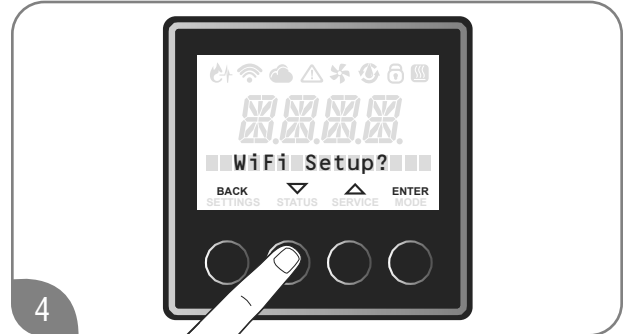

Press the “▼” or “▲” button until “WiFi Setup?” is displayed, and press “ENTER” button.



Press the “▼” or “▲” button until “Yes” is displayed, and press “ENTER” button.

WiFi signal will start to broadcast (WiFi icon will start to blink) for 30 minutes and user can use the EcoNet Application to setup WiFi.

If setup is not completed in the next 30 minutes, WiFi will stop broadcasting. User should go to these steps again to re-start WiFi setup.

Once WiFi is setup correctly, WiFi icon will become solid.

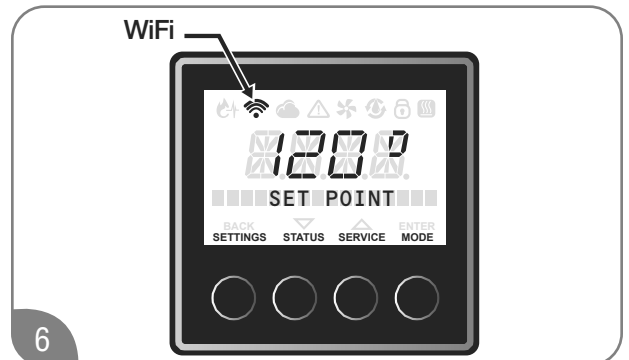

In the event that WiFi credentials are changed, please follow WiFi setup steps again.

USING YOUR WATER HEATER

WiFi Setting (cont.)

Steps to reset WiFi

These steps are to reset the WiFi chip, in the event that WiFi stops working and WiFi credentials are NOT changed.

To reset WiFi and make it try to connect to the network again,



Press the “Service” button.

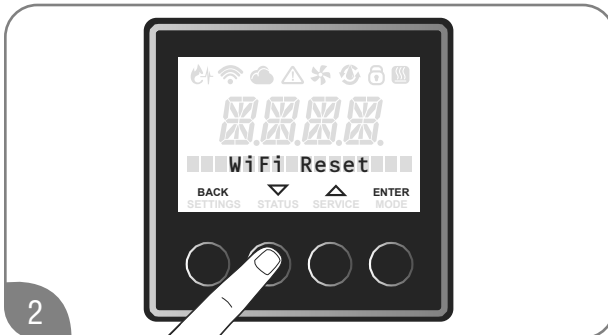

Press the “▼” or “▲” button until “WiFi Reset” is displayed, and press “ENTER” button.



Press the “▼” or “▲” button until “Yes” is displayed, and press “ENTER” button.

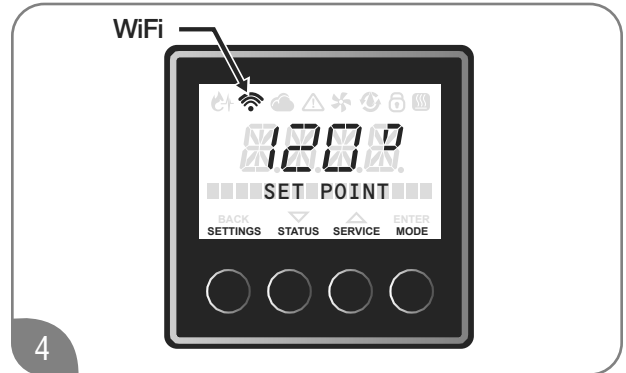

WiFi signal will reset and WiFi icon all start blinking again.

WiFi will try to reconnect to the stored WiFi network using the same credentials.

Once WiFi is connected again correctly, WiFi icon will become solid.

Models with WiFi can be monitored and controlled from the EcoNet mobile app. Scan the QR code for download.



Follow in-app instructions for setup

USING YOUR WATER HEATER

Water Saving Control

Water saving control is optional and is inactive as default. To activate this control, appropriate procedures must be followed.

Water saving control can reduce waste water at initiation of hot water demand by reducing flow until outlet hot water reaches set temperature. It is recommended to turn ON this control if the water heater is installed in a drought area or anywhere water conservation is needed.

Follow the steps below to turn ON the water saving control:

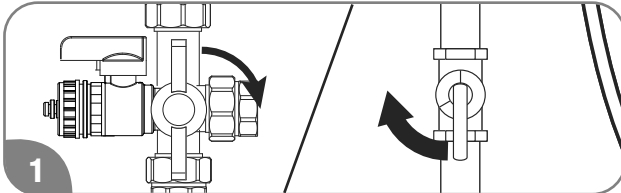

Turn off the gas and water to the water heater by closing the shut-off valves.

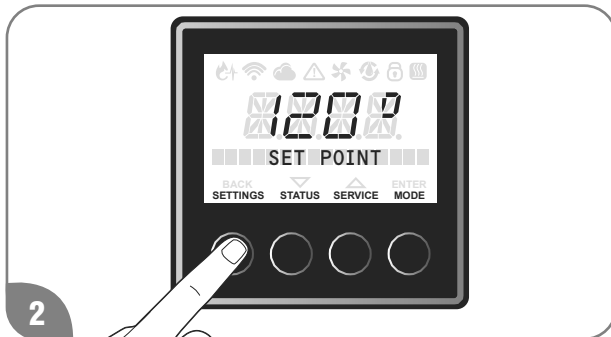

Press the "SETTINGS" button.

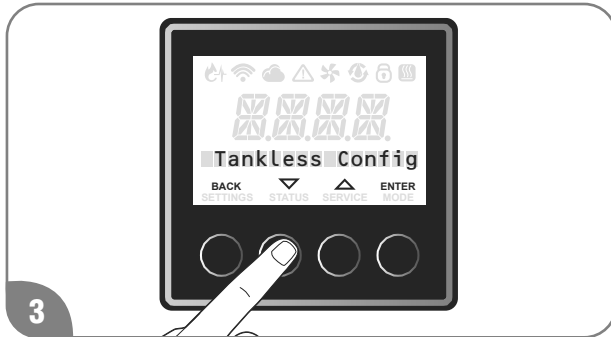

Press the "▼" or "▲" button until "Tankless Config" is displayed, and press the "ENTER" button.

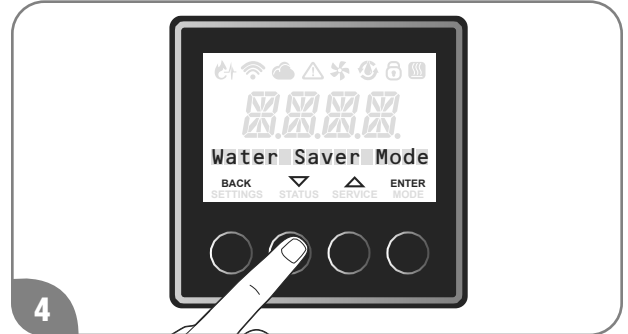

Press the "▼" or "▲" button until "Water Saver Mode" is displayed, and press the "ENTER" button.

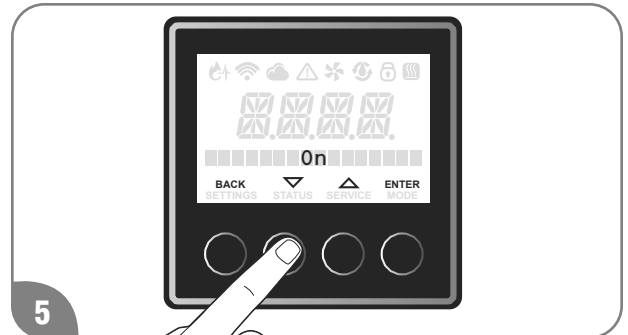

The Factory setting is "Off".

Press the "▼" or "▲" button to select "On" and press the "ENTER" button to confirm.

To exit this setting, press "Back" button until the initial screen is displayed.

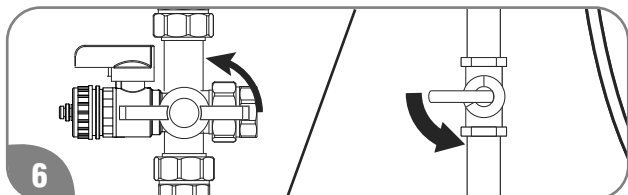

Turn on the gas and water to the water heater by opening the shut off valves.

USING YOUR WATER HEATER

Water Saving Control (cont.)

Follow the steps below to turn Off the water saver model:

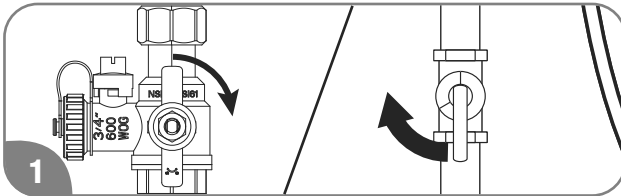

Turn off the gas and water to the water heater by closing the shut-off valves.

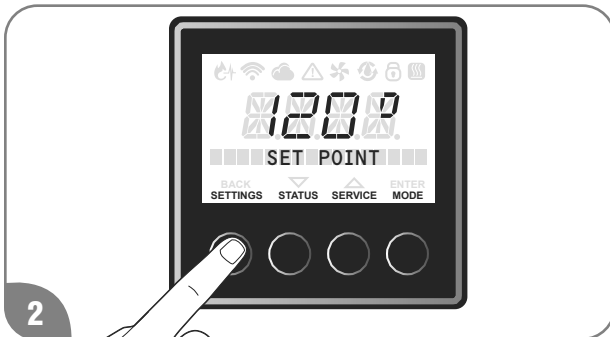

Press the "SETTINGS" button.



Press the "▼" or "▲" button until "Tankless Config" is displayed, and press the "ENTER" button.

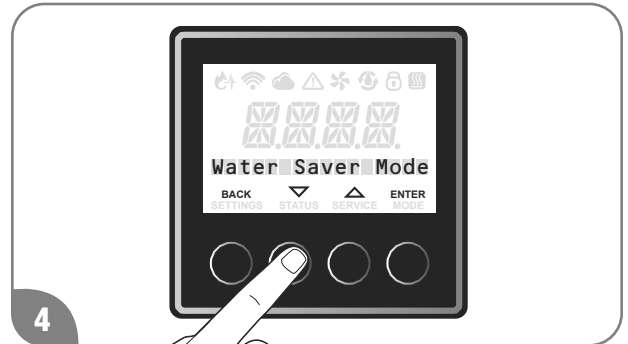

Press the "▼" or "▲" button until "Water Saver Mode" is displayed, and press the "ENTER" button.



Press the "▼" or "▲" button to select "Off" and press the "ENTER" button to confirm.

To exit this setting, press "Back" button until the initial screen is displayed.

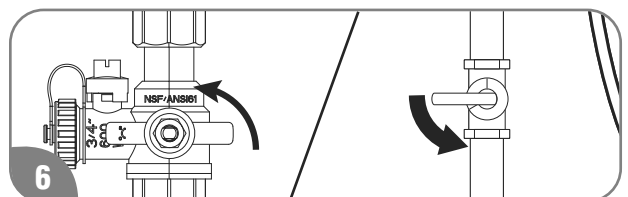

Turn on the gas and water to the water heater by opening the shut off valves.

CARING FOR YOUR WATER HEATER



Draining the Water Heater

⚠️ WARNING:

Failure to follow these draining instructions can cause serious personal injury from scalding and/or product damage.



1 Press the "MODE" button. After the LCD displays "ENABLE/DISABLE", press the "ENTER" button.



2 Press the "▼" or "▲" button until "DISABLE" is displayed, and press the "ENTER" button.

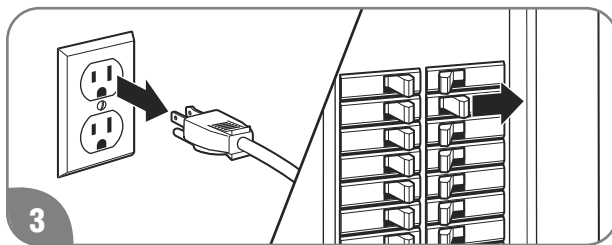

3 Turn water heater off. Unplug the water heater from electrical outlet or disconnect the power supply at the circuit breaker.

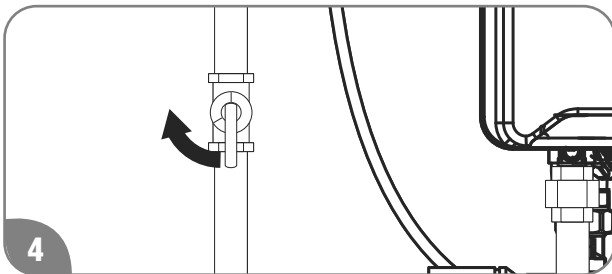

4 Close the gas shut-off valve.

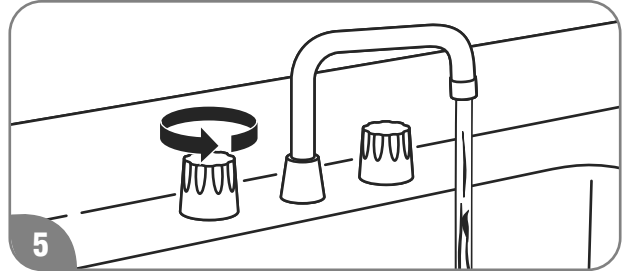

5 Open all hot water faucets. Run the water until it is COLD; then shut off the faucet.

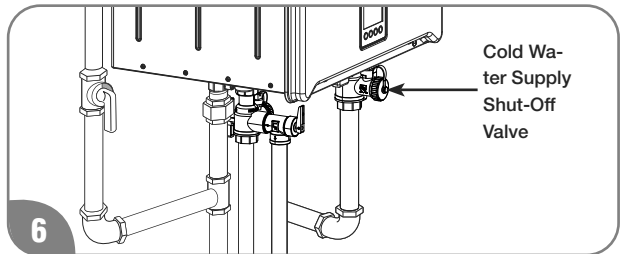

6 Close the water shut-off valve.

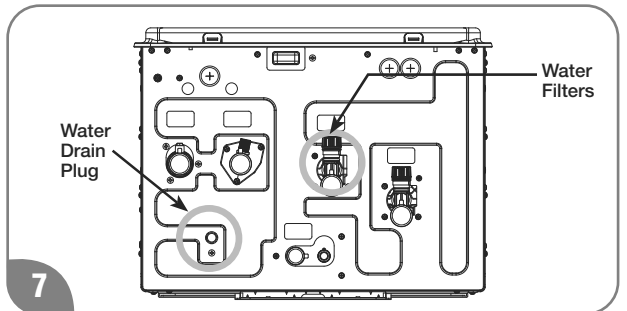

7 Find the water filter(s) and the water drain plug at bottom of the water heater.

 Only applies to built-in pump models.

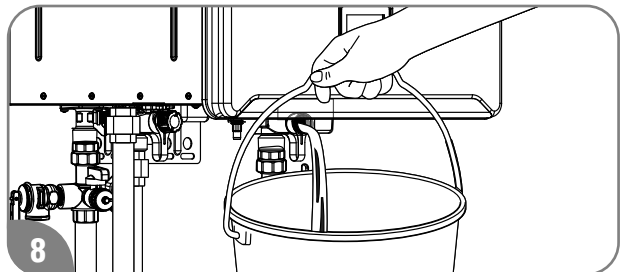

8 Using a suitable container to catch the water, remove the water drain plug located at bottom of the water heater, and the water filter(s).

CARING FOR YOUR WATER HEATER



Draining the Water Heater (cont.)

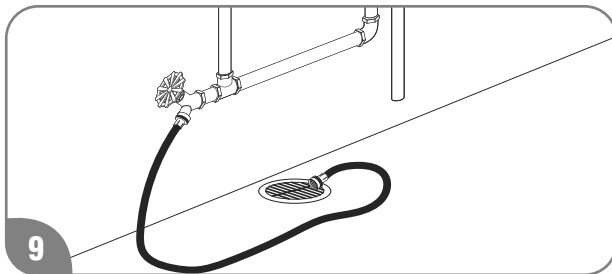

Connect a garden hose to the drain valve on the hot water outlet line and place the other end in a suitable drain. Open the drain valve until all the water has drained from the water heater. Leave water heater as is until placed back in service.

⚠ CAUTION:

Even when drained properly, a small amount of water will remain in the water heater. In cold weather conditions, this water can freeze. If this happens, allow the defrost protection on the water heater at least 30 minutes to melt the frozen water. The water heater will not work properly until this water is thawed.

To put the water heater back in service:

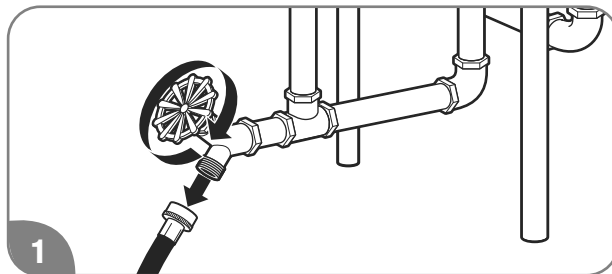

Disconnect drain hose. Make sure the drain valve is closed.

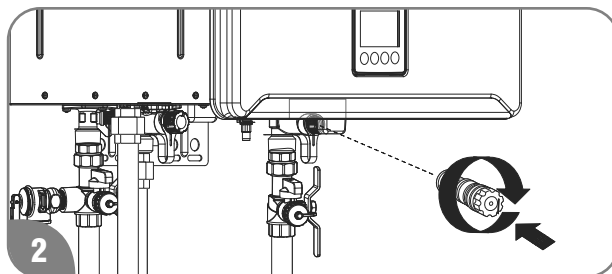

Reinstall the water filter(s), and the water drain plug.

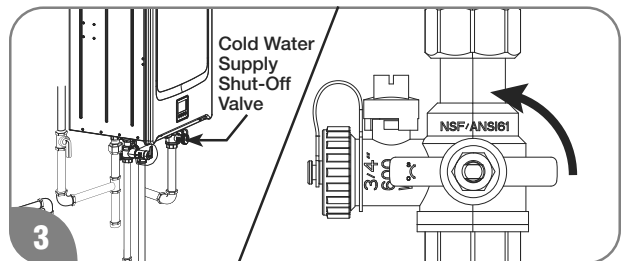

Open the water shut-off valve.

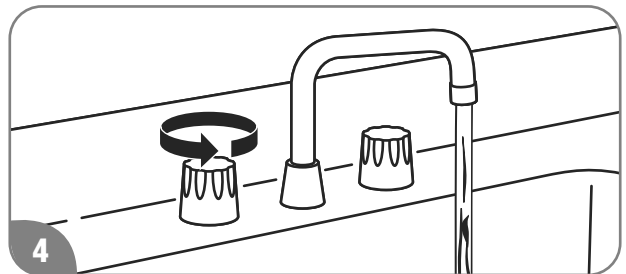

Open all hot water faucets and let run until all air has been purged from the lines. Close all hot water faucets.

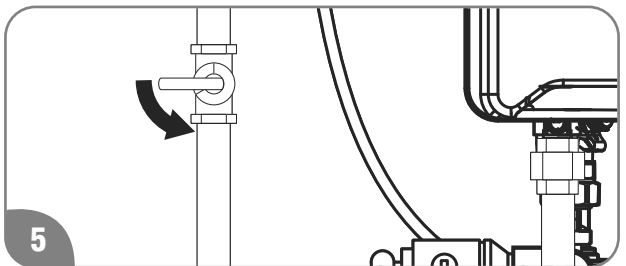

Open the gas shut-off valve(s).

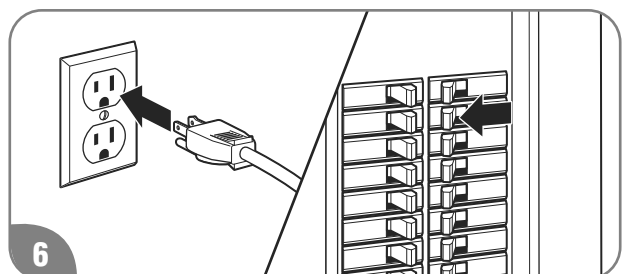

Plug in the power cord or reconnect the power supply at the circuit breaker box.

CARING FOR YOUR WATER HEATER



Draining the Water Heater (cont.)

Standard Drain Method

Service isolator valve kits may be purchased from the manufacturer, distributor, or place of purchase. The kits include two full-port isolation valves to be used in the inlet and outlet water lines. These kits provide a means for full diagnostic testing and ease of system flushing and draining.

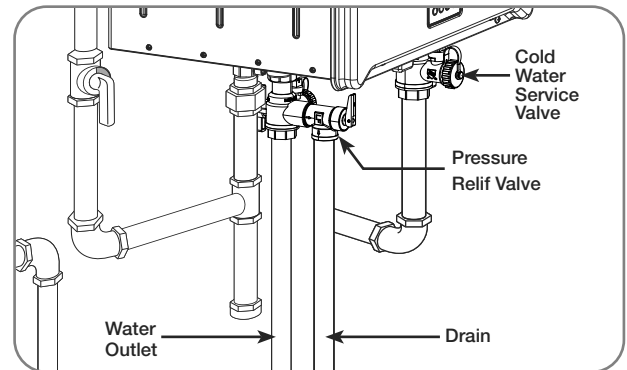

Flushing of the Heat Exchanger

Flushing of the heat exchanger is required for maintaining optimal efficiency. Flushing frequency is based on water conditions and average usage and should be conducted annually or as recommended by a professional. Failure to flush the unit consistently could result in higher operation costs or premature unit failure.

Flush kit (RTG20124) is available to conduct flushing of the heat exchanger. Contact a store where tankless water heater is purchased to purchase the flush kit.

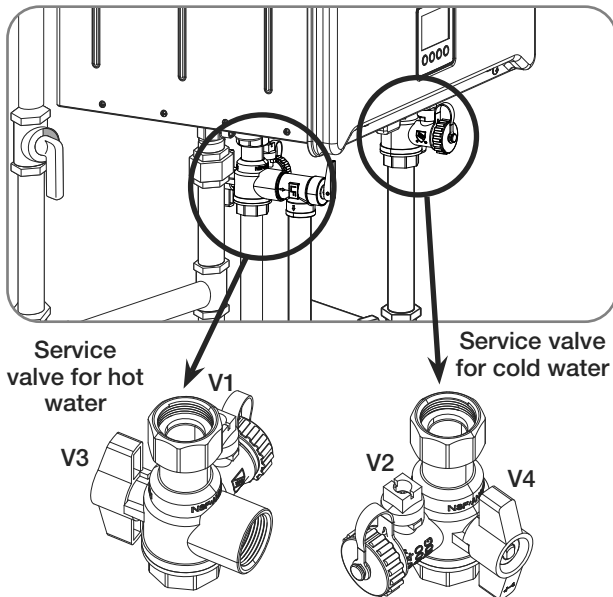

Set the highest available set point on a display. It should be 140F (60C). Follow the instructions at “Setting the Water Temperature” in this use and care manual to change set point.

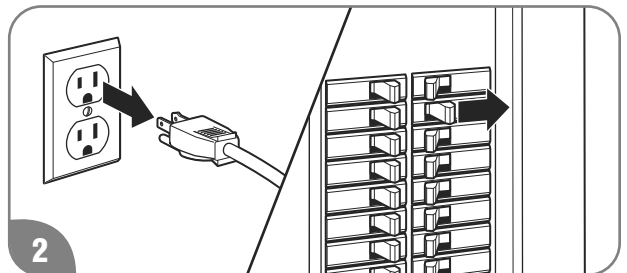

Unplug the water heater from electrical outlet or disconnect the power supply at the circuit breaker.

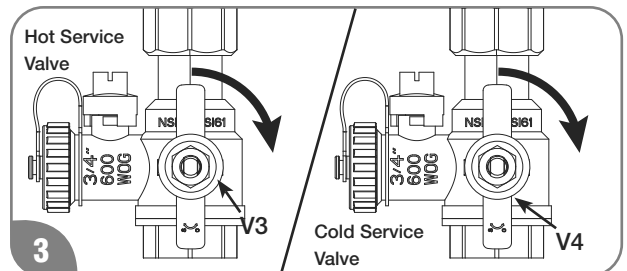

Follow the instructions at “Draining the Water Heater” in this use and care manual to drain the water heater, and close at cold and hot service valves V3 and V4.

CARING FOR YOUR WATER HEATER



Flushing of the Heat Exchanger (cont.)

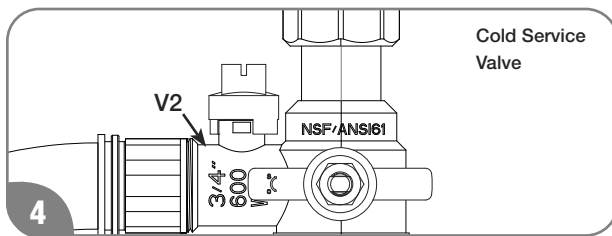

Connect one side of hose of a circulating pump contained in the flush kit to cold service valve V2, and the other side to the pump outlet.

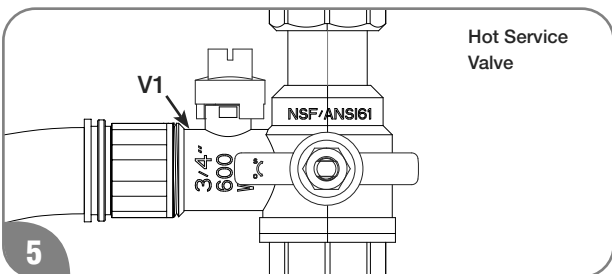

Connect one side of the drain hose to hot service valve V1, and place the other side in the bucket.

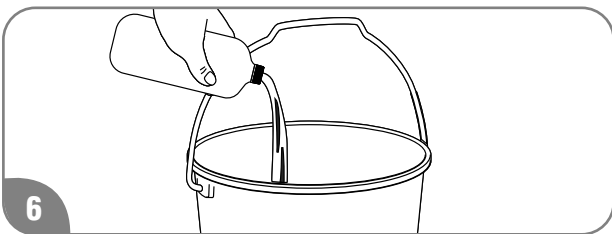

Pour no more than 2 gallons of virgin food grade white vinegar into the bucket, and place the circulating pump in the bucket.

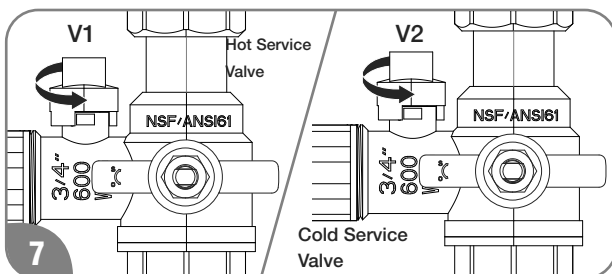

Open cold and hot service valves V1 and V2.



Connect power to the pump and allow to circulate vinegar for 45 minutes. After a minimum of 45 minutes unplug the circulating pump

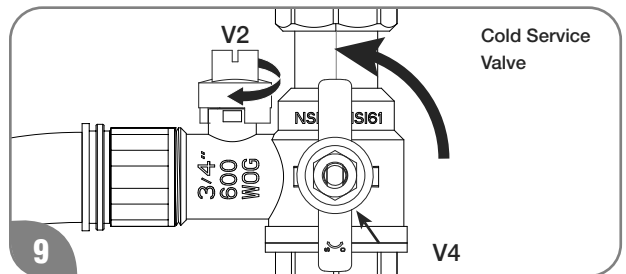

Remove the drain hose from the bucket and route it to suitable drain. Close cold service valve V2, and open service valve V4 to flush the water heater with water. **DO NOT** open hot water service valve V3 at this time. Allow water to flow out of house for 5 minutes to rinse cleaning solution.

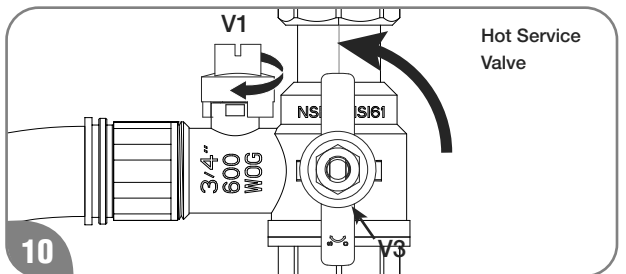

Close hot service valve V1, and open valve V3. Disconnect both hoses from service valves.

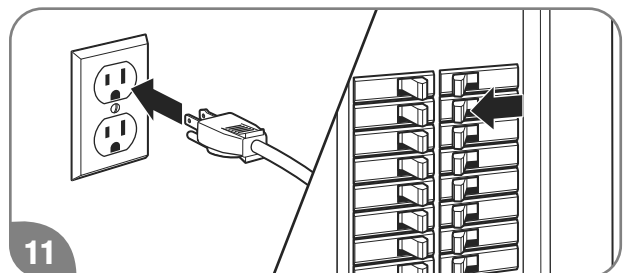

Follow the instructions at “Water Filter Cleaning” in this use and care manual to clean the water filter, and plug in the power cord or reconnect the power supply at the circuit breaker.

NOTICE:

Recommend 120°F for the temperature setting when flushing procedure is completed.

CARING FOR YOUR WATER HEATER



Service Error Code Chart

Your water heater has an electronic diagnostic system built into it. When the water heater finds a problem, it displays an error code in the LCD on the User Interface. The chart on the next page lists the error codes along with their possible problem and solution. Using this chart may help you diagnose and/or fix a problem you may be experiencing. Please refer to this chart before calling for service assistance.

⚠ DANGER:

Shock Hazard – Make certain power to the water heater is OFF before removing protective cover for any reason. Electric shock will cause death or serious personal injury.

⚠ WARNING:

For Your Safety, DO NOT attempt repair of electrical wiring, gas piping, heater control, burners, vent connectors, or other safety devices. Refer repairs to a qualified service technician.

Clearing Error Codes

When an error code is displayed:

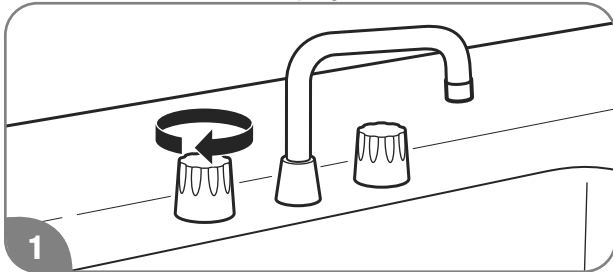

Turn off all the hot water faucets.



Press the “SERVICE” button.

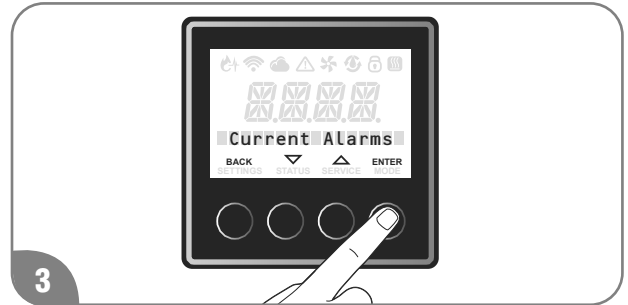

Press the “ENTER” button.

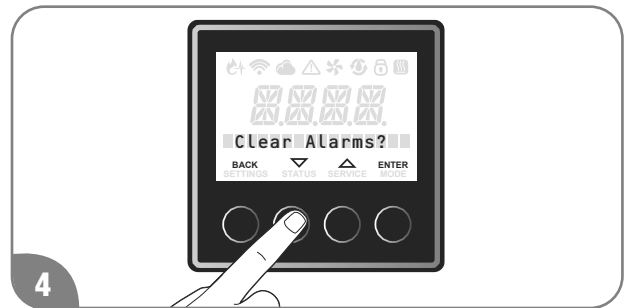

Press the “▼” or “▲” button until “Clear Alarms?” is displayed, and press the “ENTER” button.

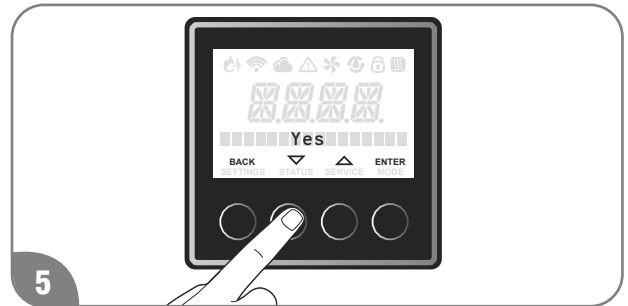

Press the “▼” or “▲” button until “Yes” is displayed, and press the “ENTER” button. To exist this setting, press “BACK” button until the initial screen is displayed.

If the error code is still shown:

1. Turn off the hot water faucet.
2. Turn off the water heater.
3. Make note of the displayed error code and call for service assistance. See “*Call for Assistance*” section on this Use and Care Manual.

NOTICE:

If the displayed error code is not listed in the chart, immediately turn off the water heater and call for service assistance.

CARING FOR YOUR WATER HEATER



Service Error Code Chart

Error Code	Possible Cause	Solution
A01L	Water heater has buildup of lime deposits.	Contact a dealer or qualified service technician.
A011	The gas shut-off valve is not fully opened.	Check shut-off valve and open completely.
A012	Gas service has been interrupted.	Contact your gas utility company.
	LP gas is running low (LP models only).	Refill or replace your LP gas container.
A014	Water heater is overheating.	Contact a dealer or qualified service technician.
A029	Blocked condensate line.	Contact a dealer or qualified service technician.
A031	Faulty inlet water thermistor.	Contact a dealer or qualified service technician.
A032	Faulty heat exchanger thermistor.	Contact a dealer or qualified service technician.
A033	Faulty outlet water thermistor.	Contact a dealer or qualified service technician.
A035	Improper thermistor connection.	Contact a dealer or qualified service technician.
A036	Faulty exhaust thermistor.	Contact a dealer or qualified service technician.
A055	Faulty gas valve.	Contact a dealer or qualified service technician.
A061	Faulty blower motor.	Contact a dealer or qualified service technician.
A063	(Built-in recirculation) pump abnormality.	"SR models" only. Contact a dealer or qualified service technician.
A065	Faulty water flow solenoid.	Contact a dealer or qualified service technician.
A066	Faulty bypass solenoid.	Contact a dealer or qualified service technician.
A070	Faulty control board.	Contact a dealer or qualified service technician.
A071	Faulty gas solenoid valve.	Contact a dealer or qualified service technician.
A072	Flame detected before ignition.	Contact a dealer or qualified service technician.
A082	Software error.	Contact a dealer or qualified service technician.
A090	Air intake or vent exhaust opening may be blocked.	Remove any blockage. (Air intake requires 12 in [30 cm] of clearance.)
	The vent pipes on the vent termination may not be connected properly.	Contact a dealer or qualified service technician.
	Blocked vent termination or inlet air filter.	Contact a dealer or qualified service technician.
T113	Not enough hot water to operate the unit.	Increase the water flow from the fixtures.
T111	Reminder of flushing the heat exchanger and/or replacing the water treatment filter	Contact a dealer or qualified service technician.

IF YOU NEED SERVICE



Call for Assistance

1. All questions, adjustments, repairs, and/or routine maintenance should be directed to your installer, plumbing contractor, or licensed service agent. If your contacts have moved or are not available, please refer to the telephone directory, commercial listings, or local utility company for qualified service assistance.
2. If your problem has not been solved to your satisfaction, contact the Manufacturer National Service Department at the following address:

Manufacturer National Service Department
 800 Interstate Park Drive
 Suite 700
 Montgomery, AL 36109
 Phone: 1-866-720-2076

When contacting the manufacturer, the following information will be requested:

- A. Model and serial number. (See page 8 or the ratings plate on the inside of the top panel of the water heater.)
- B. Address where the water heater is located.
- C. Name and address of installation contractors (page 8) and all qualified service companies that have worked on the water heater.
- D. Original installation date. (See page 8.)
- E. Dates any service or preventive maintenance was performed.
- F. Details of the persisting problem.
- G. List of businesses that have tried to fix this problem, along with dates of service.